



VELAMMAL COLLEGE OF ENGINEERING AND TECHNOLOGY

(AUTONOMOUS)

MADURAI-625009 , TAMILNADU , INDIA.



EEE

MAGAZINE



JUNE - DECEMBER 2022

PRESENTED BY

DEPARTMENT OF ELECTRICAL AND ELECTRONICS ENGINEERING

VCET

VISION AND MISSION

VISION:

To emerge and sustain as a center of excellence for technical and managerial education upholding social values.

MISSION:

- Imparted with comprehensive, innovative and value-based education.
- Exposed to technical, managerial and soft skill resources with emphasis on research and professionalism.
- Inculcated with the need for a disciplined, happy, married and peaceful life.

EEE DEPARTMENT

VISION AND MISSION

VISION:

To produce quality Electrical Engineers for industry and good citizens for society through excellence in technical education and research.

MISSION:

- To empower graduates with sophisticated knowledge and technical skills.
- To explore, create and develop innovations in Electrical Engineering and Technology.
- To provide beneficial service to the rural, state, national and international communities.

PROGRAM EDUCATIONAL OBJECTIVES:

1. Graduates will professionally be competent, excel in academics and solve wide range of problems in Electrical and Electronics Engineering field to serve the needs of Employers.
2. Graduates will engage in continuous professional development activities through Lifelong Learning to enhance technical knowledge and communication skills.
3. Graduates will excel in leadership quality and managerial capability which leads to Entrepreneur that bridge the gap between the advanced technology and the end users.

MESSAGE FROM HEAD OF THE DEPARTMENT



It gives me immense happiness to witness the creative expressions of students, who had contributed to TECHMANIA'18- Dec Issue. College life is a period of life during which students start turning out into professionals by exploring and developing their innate talents and skills. I am very glad that the department has always been unstoppable in its progress, because of the active participation of students and the huge efforts of the professors towards the progressive development of students. Our department has also been actively involved in various activities that has thrown light upon the hidden talents of our students. They stand as a witness to the monumental efforts, taken by the management to make the college a center of excellence in education and research. It is great to find a considerable number of articles, poems and art works, which stand as testimonials not only for students talents but also for their dedication and commitment in their works. I am sure that this magazine would definitely inspire and encourage all students to contribute even more to the forthcoming issues. And, I am looking forward for the upcoming issues of the magazine with a hope and a wish that it would set bench marks for student magazines.



CHIEF ADVISOR:

Dr.A.Shunmugalatha,
HoD/EEE

EDITORIAL CHIEF

Mrs.Umayal Muthu,
AP-II / EEE

STUDENT EDITORS

KANNAN B
IV EEE

RICKY S
III EEE

HARISH MITHRAN G B
II EEE



TABLE OF CONTENTS

GREAT MIND

SATYA NARAYANA NADELLA

1

PAPERS

HAND GESTURE BASED HOME APPLICATIONS-
CONTROL SYSTEM

4

SMART GARDEN MONITORING SYSTEM

10

IOT BASED DRIPS MONITORING SYSTEM

16

AACIDENT DETECTION AND ALERT SYSTEM

23

WIRELESS POWER TRANSMISSION

30

BOOK REVIEW

THE ALCHEMIST BY PAULO COELHO

33

IDIOMS AND PHRASES

37

POEM

43

TECHIE'S INGENUITY

ART

45



GREAT MIND :

SATYA NARAYANA NADELLA

SATYA NARAYANA NADELLA IS AN INDIAN-AMERICAN BUSINESS EXECUTIVE. HE IS THE CHIEF EXECUTIVE OFFICER (CEO) OF MICROSOFT, SUCCEEDING STEVE BALLMER IN 2014. BEFORE BECOMING CEO, HE WAS THE EXECUTIVE VICE PRESIDENT OF MICROSOFT'S CLOUD AND ENTERPRISE GROUP, RESPONSIBLE FOR BUILDING AND RUNNING THE COMPANY'S COMPUTING PLATFORMS.

AWARDS AND RECOGNITION:

In 2019, Nadella was named Financial Times Person of the Year. In 2015, he was awarded the Pravasi Bharatiya Samman (Overseas Indian Honour/Award) for business

EARLY LIFE:

Nadella was born in Hyderabad, India on 19th August 1967 into a Telugu Hindu family. His mother Prabhavati was a Sanskrit lecturer and his father, Bukkapuram Nadella Yugandhar, was an Indian Administrative Service officer of the 1962 batch.

Nadella attended the Hyderabad Public School, Begumpet before receiving a bachelor's in electrical engineering from the Manipal Institute of Technology (then part of Mangalore University) in Karnataka in 1988. Nadella then travelled to the U.S. to study for an M.S. in computer science at the University of Wisconsin-Milwaukee, receiving his degree in 1990. Later, he received an MBA from the University of Chicago Booth School of Business in 1996. Nadella said, "I always knew I wanted to build things."

Interest:

Nadella is an avid reader of American and Indian poetry. He has authored a book titled *Hit Refresh* that explores his life, his career in Microsoft and how he believes technology will shape the future. He announced that the profits from the book would go to Microsoft Philanthropies and through that to non-profit organizations.

Career:

Nadella worked at Sun Microsystems as a member of its technology before joining Microsoft in 1992. At Microsoft, Nadella has led major projects that included the company's move to cloud computing and the development of one of the largest cloud infrastructures in the world. Nadella worked as the senior vice-president of Research and Development (R&D) for the Online Services Division and vice-president of the Microsoft Business Division. Later, he was made the president of Microsoft's \$19 billion Server and Tools Business and led a transformation of the company's business and technology culture from client services to cloud

He has been credited for helping bring Microsoft's a database, Windows

Server and developer tools to its Azure cloud. The revenue from Cloud Services grew to \$20.3 billion in June 2013 from \$16.6 billion when he took over in 2011.

Nadella's 2013 base salary was nearly \$700,000, for a total compensation, with stock bonuses, of \$17.6 million.

He received \$84.5 million in 2016 pay.

Previous positions held by

Nadella include:

- President of the Server & Tools Division (9 February 2011 – February 2014)
- Senior Vice-President of Research and Development for the Online Services Division (March 2007 – February 2011)

- *Vice-President of the Business Division*

Corporate

- *Corporate Vice-President of Business Solutions and Search & Advertising Platform Group*

Nadella's tenure at Microsoft has emphasized working with companies and technologies with which Microsoft also competes, including Apple Inc., Salesforce, IBM, and Dropbox

In contrast to previous Microsoft campaigns against the Linux operating system, Nadella proclaimed that "Microsoft Linux", and Microsoft joined the Linux Foundation as a Platinum member in 2016.



Under Nadella, Microsoft revised its mission statement to "empower every person and every organization on the planet to achieve more". He has transformed Microsoft's corporate culture into one that emphasizes continual learning and growth.

In 2014, Nadella's first acquisition with Microsoft's was of Mojang, a Swedish game company best known for the computer game Minecraft, for \$2.5 billion. He followed that by purchasing Xamarin for an undisclosed amount. He oversaw the purchase of professional network LinkedIn in 2016 for \$26.2 billion. On October 26, 2018, Microsoft acquired GitHub for US\$7.5 billion.

**- R.SUBHIKSHA.A
III YEAR EEE-A**

SMART GARDEN MONITORING SYSTEM:

The smart garden is an innovative indoor garden. This project aims to developing smart gardening using automation and internet of things (IoT) technology. The highlighting feature of this project includes irrigation with smart control and intelligent decision making based on accurate real time field data. In this project three sensors such as soil moisture sensor, temperature and light dependent resistor sensor, level sensor has been used. The main aspect of this project is water level sensor. It senses the water level in the tank and sends the information to the microcontroller. If the water level is low water pump is turned off. The IoT allows objects to be sensed or controlled remotely across existing network infrastructure, creating opportunities for more direct integration of the physical world into computer-based systems, and resulting in improved efficiency, accuracy and economic benefit in 17 addition to reduced human intervention

METHODOLOGY:

- *When power supply is ON, the input module of three sensors starts to activate.*
- *When sensors get ON, the Arduino module will activate.*
- *If Moisture level is low, the motor 1 is operated and it water the plant.*
- *If Water level is low in tank, motor 2 is turn on and temperature sensor sense the motor temperature and it turn off the whole system.*
- *The information is send via by wifi hotspot through server and it store in cloud.*

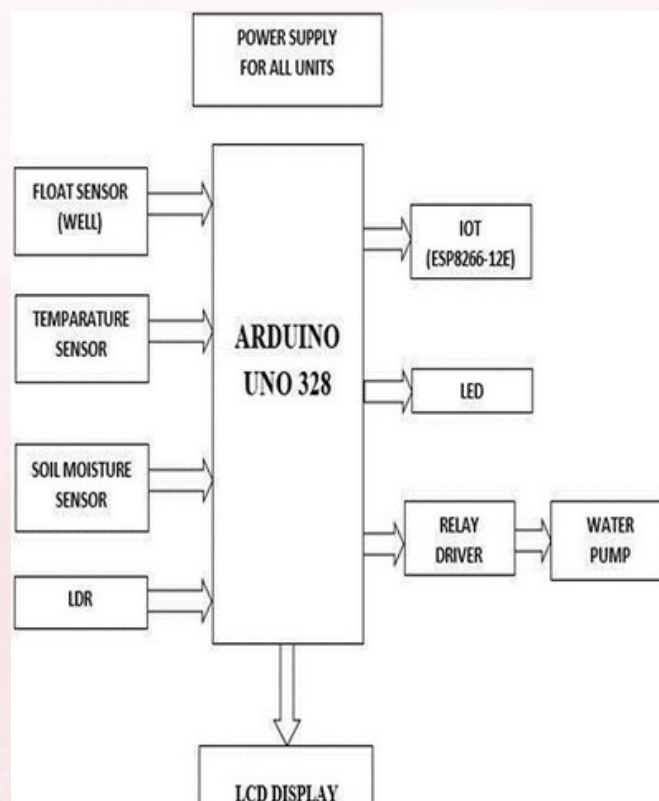

Smart garden monitoring system using IoT with the help of a micro controller helps to ease the most tedious job of gardening for plant lovers who are in a time of rush. This system monitors various garden parameters. View the information through the LED display. It also helps to solve many issues occurring in the existing plant watering and gardening system

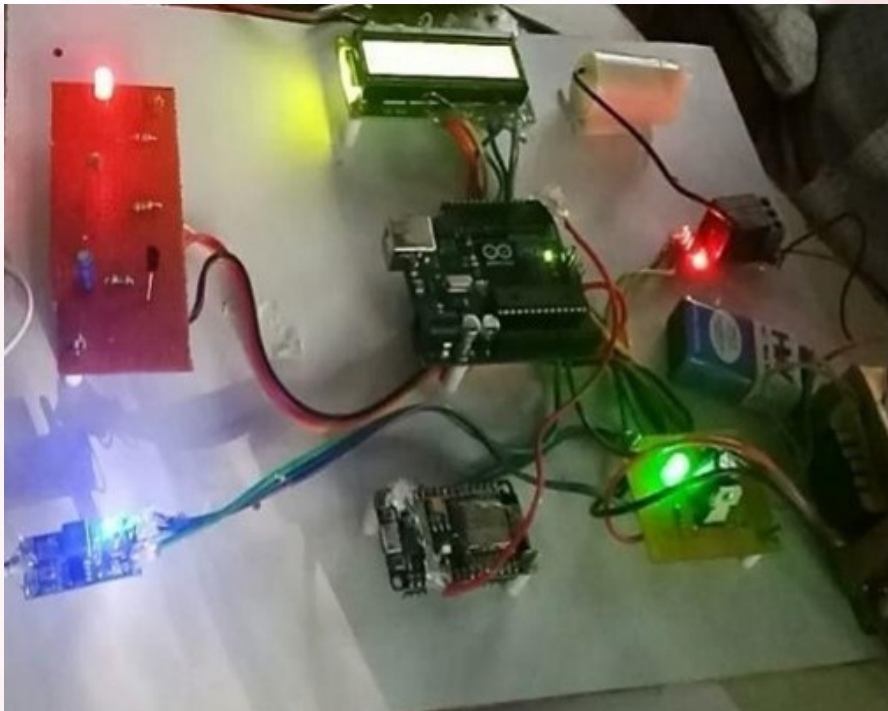

The user can control and monitor the environment of the garden using the Arduino microcontroller. The controller in this system (Arduino) provides an economic and efficient platform to implement the plant monitoring and smart gardening system using IOT.

The main advantage of the smart gardening system is that the user can monitor the garden using the internet from far distances during leisure time or whenever necessary. The main aspect of this project is water level sensor. It senses the water level in the tank and sends the information to the microcontroller. If the water level is low Water Pump is turned OFF.

Here the manual intervention can be reduced by watering the plants automatically and the whole information about the garden can be viewed in LED display In future we can improve the module with some extra features. This module will be embedding with home automation module to make an advanced home automation system. So it will help the people to do their all home related works.

In future, world will become engage so that people have no time to do gardening.

At that time, by combining this module to smart home automation module, that will help the people and many people will come forward to do gardening due to smart gardening module may be this will be the beneficial and user friendly.

In future we can add some features to kit such that it will detect the plant disease and supply the fertilizers and also maintain the plants health in good condition. This system automates plant monitoring and smart gardening using IoT platform. The main purpose of automation is to provide comfort to the people by reducing the manual work and to improve the overall performance of any system without the user interactions. The important parameters for the quality and productivity of the plant growth are soil and air temperature, humidity, sunlight and soil moisture. Information to the user about the plant health and growth may be provided to the user by continuously monitoring and recording these garden parameters.

The system is designed not only monitors the sensor data , like moisture, temperature and ultrasonic but also actuates other parameters according to the requirement for example , if the water level in the tank is reduced to a minimum value then the motor switch is turned on automatically to the water level of the tank reaches the maximum value. The initial installation of this system is cheap and hence it can be implemented anywhere. Compact smart garden monitoring system which will control and monitor different parameters of the garden and take care of it efficiently.

**-D.HENCY GLADYS
II YEAREEE-A**

HAND GESTURE BASED HOME APPLIANCES CONTROL SYSTEM:

Due to advancement in technology, there is an improvement in living standard by automating even simple task to complex tasks. User satisfaction and comfort is the main criteria for home automation. Most of the electrical appliances in every modern household are automated providing security, improving the quality of life and providing more comfort. Home automation is the popular as the home appliances are controlled using automation technology remote control and internet. The aim of this project is that disorder people can easily access this without any other person's help.

A gesture is scientifically categorized into two distinctive categories:

- Dynamic
- Static.

Gesture recognition is interpretation of human motion by the controller that contains accelerometers to sense tilting and acceleration of movement. Hand Gesture Recognition is a dynamic area of research. For different applications, different gesture recognition techniques are used.

The basic purpose of this system is to provide a means to control electronic devices (capable of infrared communication) using hand gestures.

The detected and recognized hand gestures are used as the command signals for controlling devices, some user interfaces, e.g., icon-based interface or motion-based interface, that are adjusted accordingly to support natural hand control.

METHODOLOGY

This project is designed to control electronic device based on free air hand gesture technology. XYZ accelerometer is used for home appliances control system. The accelerometer in the mobile device provides the XYZ coordinate values, which is used to measure the position and acceleration of the device. The XYZ coordinate represents direction and position of the device at which acceleration occurred. The system consists of accelerometer, microcontroller, gesture identifying and control module with micro electromechanical system sensor and home appliances control. This system is a presentation of the design implementation of real time hand gesture based home appliances control system.

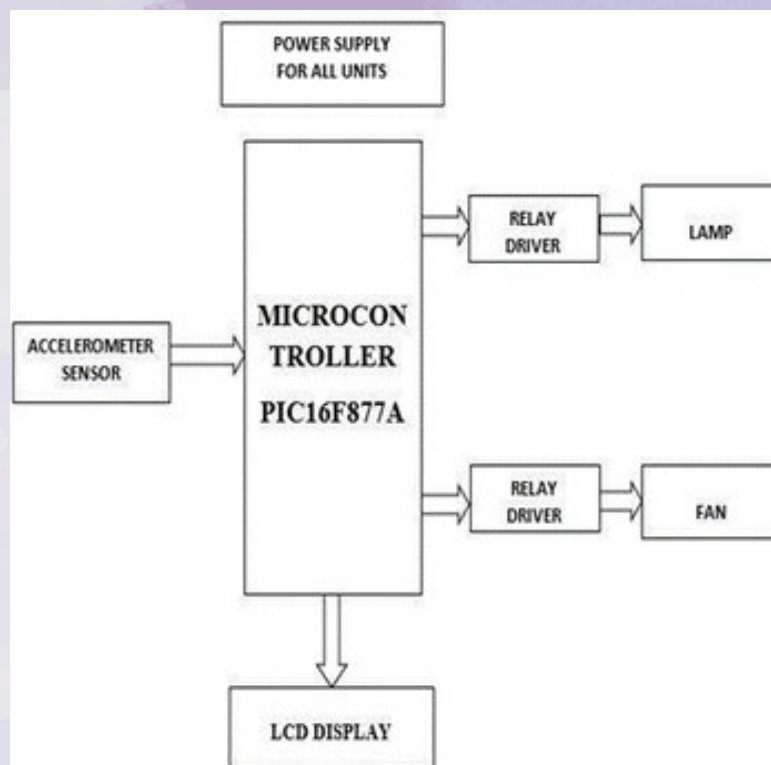

NPN transistors are used to activate the light and fan. Here the software used is MPLAB IDE software. MPLAB X is the latest edition of MPLAB, and is developed on the Net Beans platform. MPLAB and MPLAB X support project management, code editing, debugging and programming of Microchip 8-bit, 16-bit and 32-bit PIC microcontrollers. The input of an electric bulb is 220 volts ac and that of fan is 12 volts dc, but we get 5 volts output from microcontroller. So programmable logic control is used. This programmable logic control works on relay concept.

CORE FEATURES

- High performance RISC CP
- Only 35 single word instructions to learn
- Operating speed: DC- 20MHz clock input DC- 200 ns instruction cycle
- Interrupt capability (up to 14 external/internal)
- Eight level deep hardware stack • Direct, indirect and relative addressing modes
- Wide operating voltage range: 2.5v - 5.5v
- High sink source current: 25mA

PERIPHERAL FEATURES

- Synchronous Serial Port (SSP) with SPI (Master mode) and 12C (Master/ Slave)
- Universal Synchronous Asynchronous Receiver Transmitter (USART/SCI) with 9-bit address detection
- Brown – out detection circuitry for Brown out Reset (BOR)

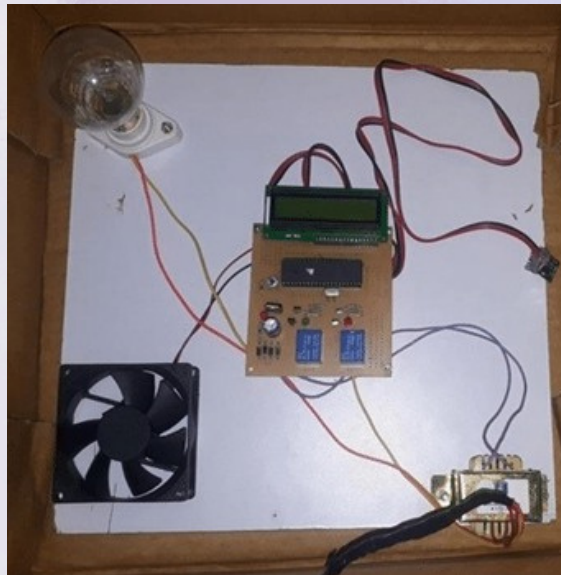

With this technology, any device can be controlled from the user end. It is able to bring a reliable assistance and security in electronic sector. In future more, home appliances can be controlled by incorporating those devices with newer versions of gestures, also implemented in every home at low cost. The device helps the people who have less mobility.

**- MIRNALINI M
II YEAR EEE-A**

IoT BASED DRIPS MONITORING SYSTEM

Better health is the central to human happiness and well-being. Patients' safety is the fundamental to provide that happiness and it is the absence of preventable harm caused to the patient at the time of health care.

WHO's work on 'Health and development' tries to make sense of these complex links. It is concerned with the impact of better health on development and poverty reduction, and conversely, with the impact of development policies on the achievement of health goals. In particular, it aims to build support across government for higher levels of investment in health, and to ensure that health is prioritized within overall economic and development plans

.
In this context, 'health and development' work supports health policies that respond to the needs of the poorest group.

WHO also works with donors to ensure that aid for health is adequate, effective and targeted at priority health problems. Every point in the process of care-giving contains a certain level of harm or uncertainty.

It is that intelligence which has to be inculcated with care to prevent unnecessary risk during monitoring.

With increase in population, there is an equal increase in mortality. Doctors use saline IV to replenish flush wounds, deliver medications and sustain patients throughout different therapies or surgeries.

Currently, Technologies have always been changing for every sector creating wonderful tools and resources that makes our lives easier, better and faster. Today everyone is going for digital transformation. While information

bottle. Indications and alert will be made thrice to the nurses for the comfort through LED bulbs in patients' room and by calls and messages to all the nurses at duty.

Better health is the central to human happiness and well-being. Currently, Technologies have always been changing for every sector creating wonderful tools and resources that makes our lives easier, better and faster.

Today everyone is going for digital transformation. And of course, the healthcare industries are going to have a dramatic change in their services.

Due to which the way of service offering patients will soon be going to change and the outcomes are going to be very much result oriented. If IV is not monitored in the right way, it may cause backflow of blood once it becomes empty which becomes dangerous for the patient.

THE MAIN OBJECTIVES ARE ::

- To monitor the fluid level by the Load cell and HX711 amplifier.
- To avoid harms caused to patients health due to negligence towards saline completion.
- To make the saline monitoring automatic and to inform the doctor/nurse spontaneously for patient safety.

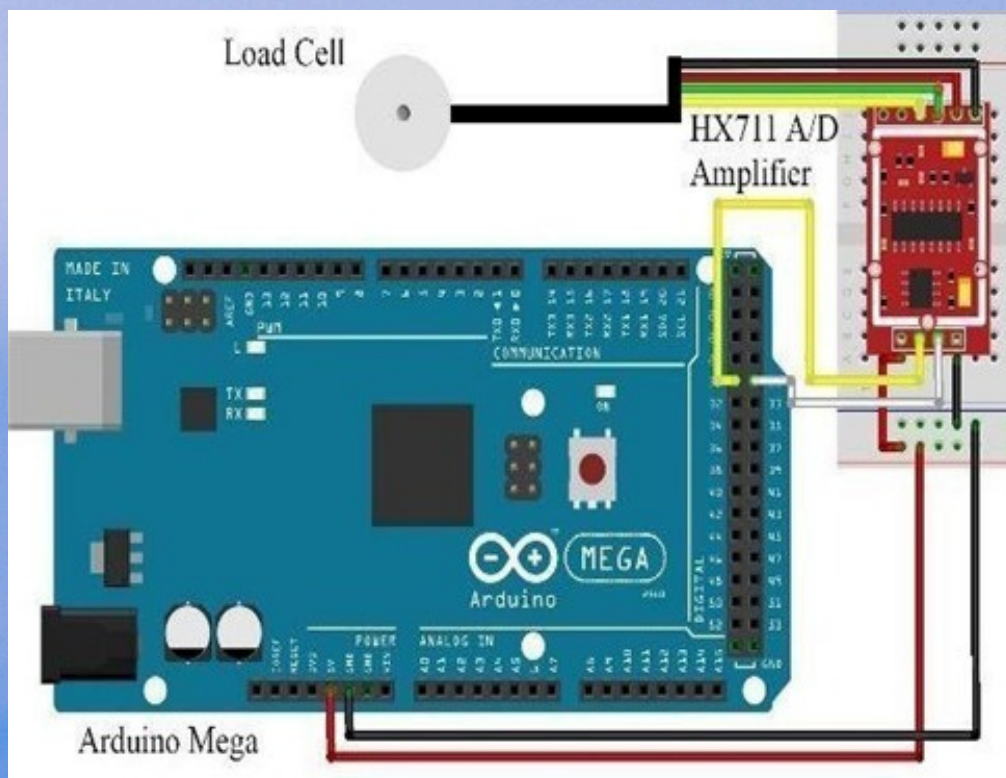

be fixed on the saline stand with the load cell amplifier HX711. The saline bottle will be hanged at the centre of the load cell so that it can measure the weight of the bottle.

Arduino Uno will be in the patient's room and once the bottle has reached to 40 percent of saline , the arduino will be activated and it glows the LED bulb (red color to indicate emergency) which will be placed in front of the patient's room.

By this way, anyone passing the room will be able to identify that it is an emergency and intimate the nurses nearby.

Later when the saline level reaches to 20 percent, Arduino will alert GSM Sim 800a used to send a message to mobile phones of all the nurses in duty indicating the need to change the saline bottle.

This will hence give time for the nurses to replace the bottle accordingly.

The Drips bottle will be connected or hanged to the load cell. The load cell which is in turn connected to the load cell amplifier HX711. Initially the saline level will be full. The amplifier is connected to the microcontroller Arduino AT Mega 328. he outputs of the Arduino are given to GSM module sim 800a and LED bulb. The GSM module is

connected here which can be further used for the process of sending messages or calls to the nurses and doctors. An automated Saline monitoring system will thus be very much accurate due to 1kg load cell.

It will help us monitor patients at regular intervals of time through different alerts.

It will also keep the nurses free from haste and panics. It is very beneficial and cost effective. Moreover this will never go unnoticed since alert is given to multiple mobile phones via messages and calls.

In future, we are planning to expand this project to ensure that multiple patients are benefited via a single message by employing IoT and use Machine learning

to monitor the patient 24/7 with the help of a camera and inform the doctors about the patients.



-S.INDUMATHI
II YEAR EEE-A

Accident detection and alert system:

In present days the rate of accidents are increasing rapidly. Due to employment the usage of vehicles like cars, bikes are increased. Because of this reason the accidents can be happened due to over speed. People are going under risk because of their over speed. Due to unavailability of advance techniques, the rate of accidents can't be decreased. To reduce the accident rate in the country this project introduces an optimum solution.

Vehicle tracking system main aim is to give security to all vehicles. Accident alert system main aim is to rescuing people in accidents. This improved security system for vehicles. The main objective is to control the accidents by sending a message to the registered mobile or to the emergency services using wireless communication techniques.

When an accident occurs at a city, the message is sent to the registered mobile through NODE MCU ESP8266-12E. This will help in finding the location of accident spot.

LCD DISPLAY

An LCD is a small low cost display. It is easy to interface with a micro-controller because of 30 an embedded controller (the black blob on the back of the board). This controller is standard across many displays which means many micro-controllers have libraries that make displaying messages as easy as a single line of code. LCDs with a small number of segments, such as those used in digital watches and pocket calculators, have individual electrical contacts for each segment. An external dedicated circuit supplies an electric charge to control each segment. This display structure is unwieldy for more than a few display elements.

VIBRATION SENSOR

Vibration sensors are sensors for measuring, displaying, and analyzing linear velocity, displacement and proximity, or acceleration.

Vibration in a rotating and/or reciprocating machinery system is, simply put, the back- and-forth movement or oscillation of the machines and components that make up the system.

While vibration in industrial equipment is often a normal part of machine operation, it also can be a sign – or the cause – of a problem.

If left unchecked, the increasing vibration can cause a progressively deteriorating fault condition, leading to asset component damage – or even a catastrophic failure.

Proactive vibration monitoring is the best course of action to prevent catastrophic failures, reduce downtime, and lower maintenance costs. And a vibration sensor is the most effective means for vibration monitoring.

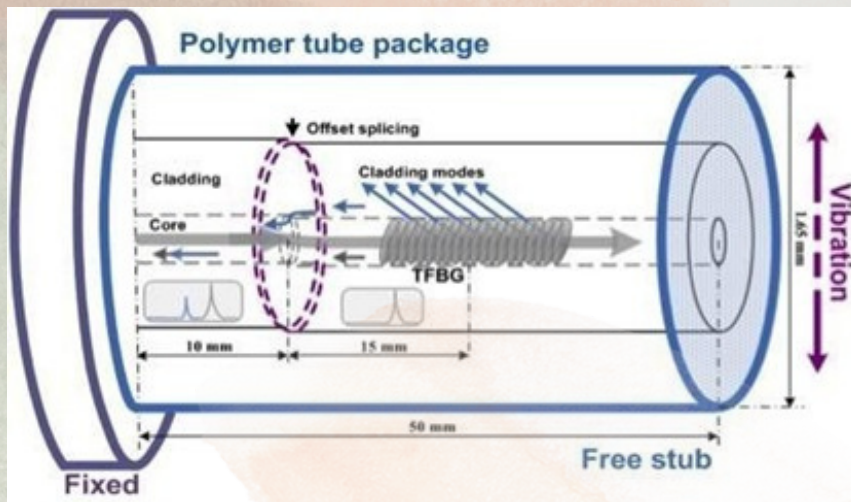

SINGLE DIODE RECTIFIER

A single diode can be used as a rectifier but this produces half-wave varying DC which has gaps when the AC is negative. It is hard to smooth this sufficiently well to supply electronic circuits unless they require a very small current so the smoothing capacitor does not significantly discharge during the gaps. Please see the Diodes page for some examples of rectifier diodes.

OUTPUT

half-wave varying DC (using only half the AC wave):



REGULATOR

Voltage regulator ICs are available with fixed (typically 5, 12 and 15V) or variable output voltages. They are also rated by the maximum current they can pass.

Negative voltage regulators are available, mainly for use in dual supplies. Most regulators include some automatic protection from excessive current ('overload protection') and overheating ('thermal protection').

The LM78XX series of three terminal regulators is available with several fixed output voltages making them useful in a wide range of applications.

The voltages available allow these regulators to be used in logic systems, instrumentation, HiFi , and other solid state electronic equipment.

Although designed primarily as fixed voltage regulators these devices can be used with external components to obtain adjustable voltages and current.

BUZZER

It most commonly consists of a number of switches or sensors connected to a control unit that determines if and which button was pushed or a preset time has lapsed, and usually illuminates a light on the appropriate button or control panel, and sounds a warning in the form of a continuous or intermittent buzzing or beeping sound.

Initially this device was based on an electromechanical system which was identical to an electric bell without the metal gong.

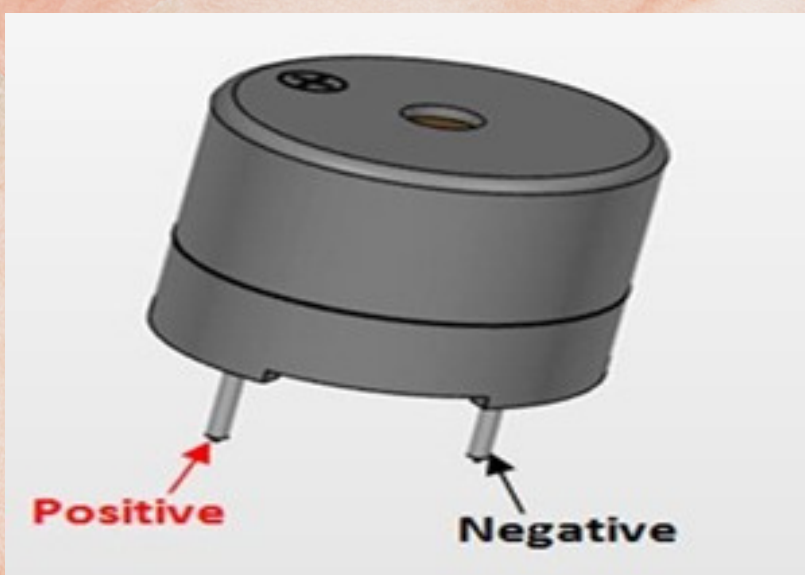

VIBRATION SENSOR

This sensor buffers a piezoelectric transducer. As the transducer is displaced from the mechanical neutral axis, bending creates strain within the piezoelectric element and generates voltages.

This sensor uses the piezoelectric effects while measuring the changes within acceleration, pressure, temperature, force otherwise strain by changing to an electrical charge.

DESIGN OF THE PROJECT

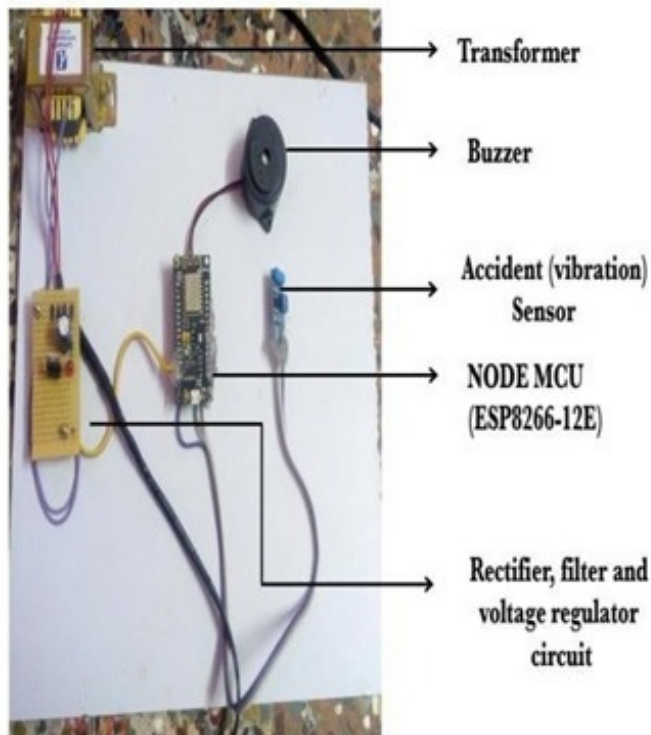

M. SWATHY
III YEAR EEE- A

WIRELESS POWER TRANSMISSION



Power transformers are one of the most important electrical equipment that are used in power transmission system as they perform the function of transforming the voltage levels. Hence maintenance of power transformer is mandatory; as they are located at different geographical areas periodical monitoring is not possible all the time due to insufficient man power. Due to this reason transformer failure may occur which leads to unexpected power shutdown. To overcome this shutdown due to transformer failure we proposed a system form on it the transformer .The aim of our project is to monitor and protect oil quality,

A temperature, and current ,fuse open or closed and voltage level of transformer without involving man power. If any critical condition occurs the SMS will be send to the operator through GSM modem as well as any faulty condition occur then fault is directly display on the LCD .This monitoring system consist of PIC 18F4550 A microcontroller, LM35 temperature sensor, fuse ,current transformer, voltage transformer, light dependent resistor (LDR),GSM modem and LCD.

WIRELESS POWER TRANSFER CIRCUIT WORKING

The wireless power transmission can be defined as the energy that can be transmitted from the transmitter to a receiver through an oscillating magnetic field. To accomplish this, power source (DC current) is changed into high-frequency AC (Alternating current)

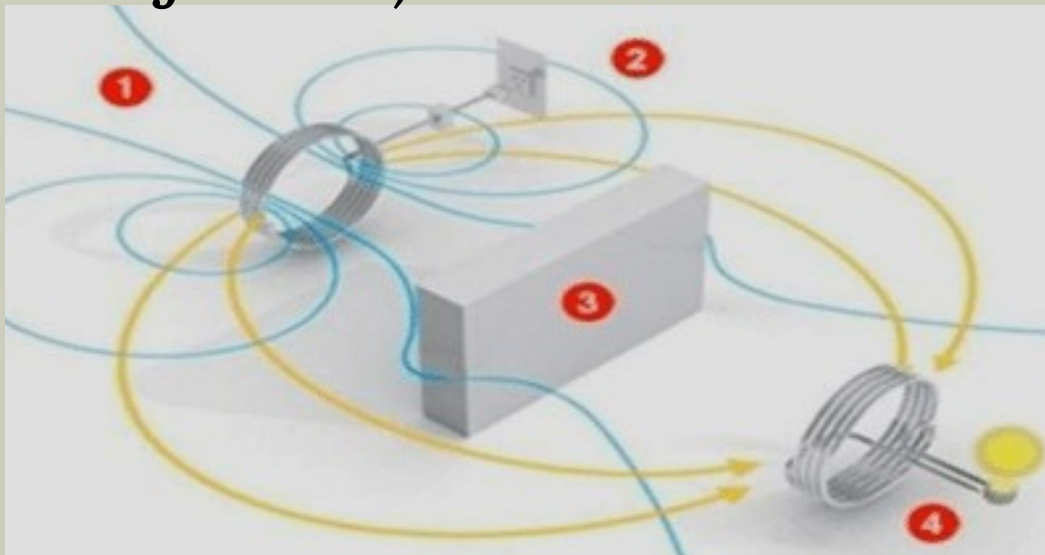

By particularly designed electronics erected into the transmitter. The AC boosts a copper wire coil in the transmitter, which produces a magnetic field. When the receiver coil is placed in proximity of the magnetic field, the magnetic field can make an AC (alternating current) in the receiving coil. Electronics in the receiving coil then alter the AC back into DC which becomes operating power.

RESONANCE & WIRELESS POWER

Some researchers at MIT found a better way to transmit power between coils that are kept a few meters apart. They also claimed to increase the distance between the coils by adding resonance to the equation.

Resonance can be defined as the frequency of a device when it vibrates naturally. The resonance of a device greatly depends on the size and shape of it.

APPLICATIONS

- *Moreover, the WPT technique can be used to charge gadgets like mobile phones, laptop batteries, iPods, propeller clock, etc. And also this sort of charging offers a far lower risk of electrical shock.*

*V. BALAJI,
IV YEAR EEE-B*

BOOK REVIEW

THE ALCHEMIST BY PAULO COELHO

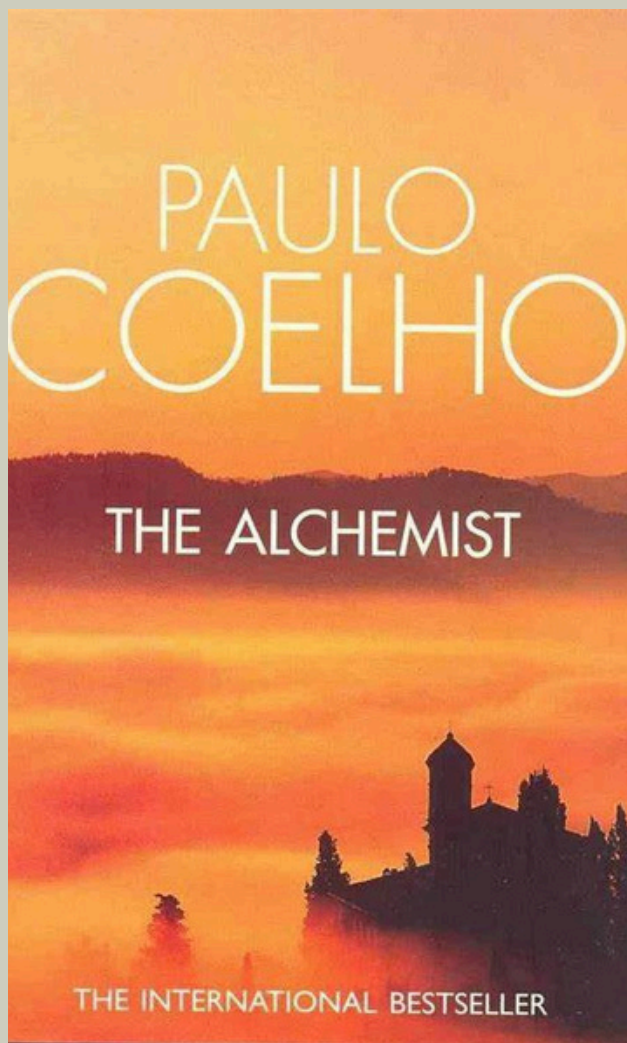

Written by Brazilian author Paulo Coelho in 1988. It was initially written and published in Portuguese. It is an international bestseller and has been translated to more than 70 languages. The book is relatively short having around 167 pages only. The theme is about finding one's destiny or purpose in life

PLOT

The story is about a Shepherd boy from Spain whose name is Santiago. He keeps getting the same dream about treasures that are lying in the Pyramids of Egypt. He embarks on a journey to follow his dream after meeting an old king who offers him magic stones and advice. Santiago crosses the Mediterranean and Sahara to find his treasures in Egypt and also accomplish his personal legend which is his purpose in life. The book details his journey and the various encounters that he experiences when following ~~his~~ **MY THOUGHTS**

The Alchemist is a fantastic book and the storytelling is beautiful. The choice of words are impeccable, full of wisdom and philosophy .I totally loved it . The story is very enchanting and bursts with optimism which I think is very important in our lives .The book shows that the journey to your destiny is as important as the destiny itself. I love how the book emphasizes on the importance of faith, hope and spirituality through the story of an ordinary boy.

FAVOURITES QUOTES FROM THE BOOK

Love is not to be found in someone else but in ourselves; we simply awaken it. But in order to do that, we need the other person.|| Paulo Coelho, The Alchemist

One is loved because one is loved. No reason is needed for loving.|| Paulo Coelho, The Alchemist

You can become blind by seeing each day as a similar one. Each day is a different one, each day brings a miracle of its own. It's just a matter of paying attention to this miracle. Paulo Coelho,

||

The Alchemist

It's the possibility of having a dream come true that makes life interesting.|| Paulo Coelho, The Alchemist

There is only one thing that makes a dream impossible to achieve: the fear of failure. Paulo Coelho, The Alchemist.

About the Author

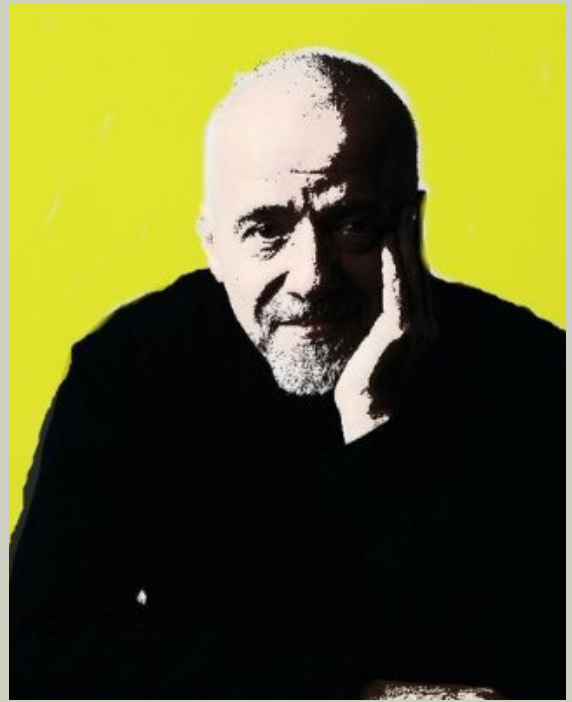

Paulo Coelho is a Brazilian author. When Coelho was 38 years old, he had a spiritual awakening in Spain and wrote about it in his first book, *The Pilgrimage*. It was his second book, *The Alchemist*, which made him famous. He's sold million copies and now writes about one book every two years.

A.YAAZHINI
IV year EEE-A



*Idioms
and
Phrases*

1. Wholebagoftricks

Meaning :

Meanstrying all the clever means to achieve something

Example :

It was really difficult to find the information even after applying the whole bag of trick.

Origin:

In the fable of 'The Fox and the Cat,' as by the Brothers Grimm (and in a slightly different fashion by Aesop), the fox boasts that he is 'master of a hundred arts, and have into the bargain a sackful of cunning.' (In Aesop he says 'a hundred shifts,' meaning expedients.) They did not serve the fox well; when dogs chased the fox and cat, the cat reached safety by climbing a tree, but the fox was caught. 'Open your sack, Mr. Fox, open your sack,' the cat cried, but it was too late." From "The Dictionary of Clichés" by James Rogers (Wings Books, Originally New York: Facts on File Publications, 1985).

2. Get ducks in a row

Meaning:

Getting your things well organized.

Example :

To ensure a successful product launch, we must get our ducks in a row.

Origin:

To get one's ducks in a row means to take care of one's duties and responsibilities, to organize one's affairs. Get one's ducks in a row and have one's ducks in a row are American idioms; the origin of these phrases is murky. One possible origin is a lawn bowling game that was popular in the 1700s, which involved setting up duck pins, obviously, in a row. Another possible inspiration for the term get one's ducks in a row is the way in which tin ducks are lined up in a shooting gallery

3. Think on your feet

Meaning :

Adjusting quickly to changes and making fast decisions

Example:

A good sales man must be able to think on his feet to close the deal

Origin:

This expression is thought to have originated in 16th century but it actually became popular and common in 18th century. It is observable that when you clump or tramp your foot on ground, it means to demand someone's attention. It also means to express a strong demand of something. The origins of this bizarre phrase are obscure, though it was first recorded in 1651 in the poet Henry Vaughan's collection *Olorlscanus*. Speculation as to its origins ranges from medieval superstition to Norse

4.Waiting in the wings

Meaning:

Waiting for an opportunity to take action, mostly to replace someone else in their job.

Example:

The senior manager is going to retire in next 2 months. Two of his juniors who are waiting in the wings will have a fierce competition.

Origin:

The "wings" are the areas just offstage, left and right, in a theatre, where actors who are not onstage get ready to enter and perform. So the phrase means to wait for one's turn to take part, particularly the kind of waiting where a "cue" tells you it's time to enter. It's applied metaphorically to all kinds of patient waiting for an opportunity. "The Turkish army is waiting in the wings while the other armies fight the initial battles



5. Straight from the horse's mouth



Meaning:

Getting information directly from the most reliable source

Example: :

I never would've believed she got expelled from her boarding school if I hadn't heard it straight from the horse's mouth.

Origin :

This one is said to come from the 1900s, when buyers could determine a horse's age by examining its teeth. It's also why you shouldn't —look a gift horse in the mouth,|| as inspecting a gift is considered bad etiquette.



By,

**R.N.S.
VENKATESH**

III YEAR EEE-B



POEM

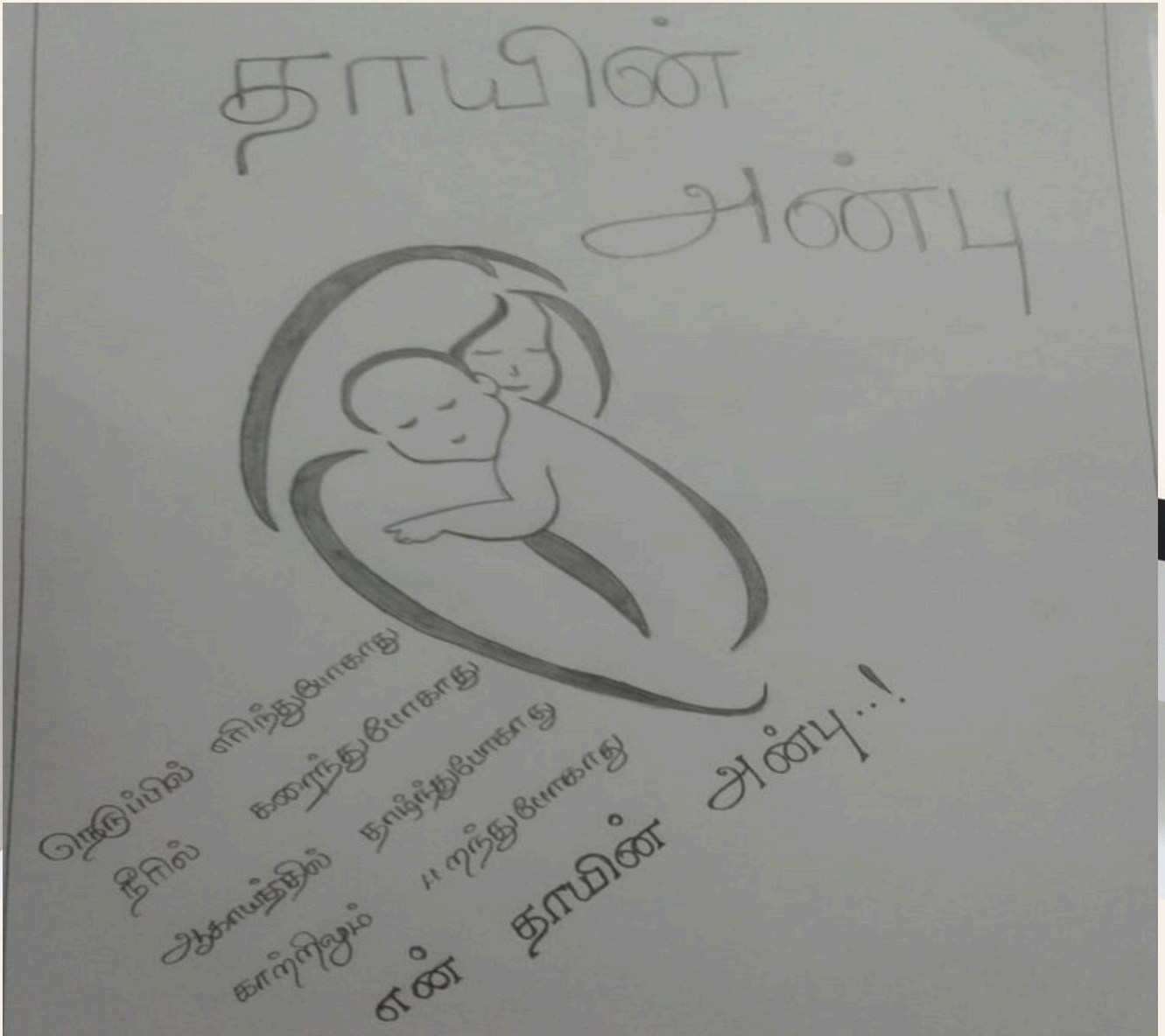

**J.JEYA VINISHA
II YEAREEE A**

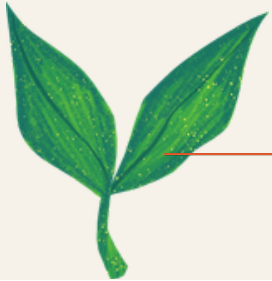



Techie's Ingenuity

ART

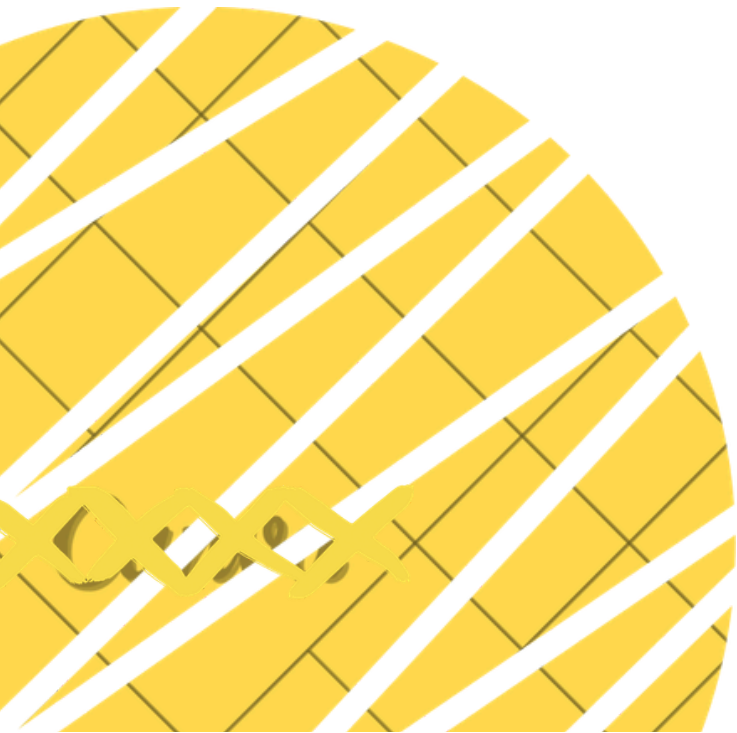



P.JANANIPRIYA
IYEAR EEE A

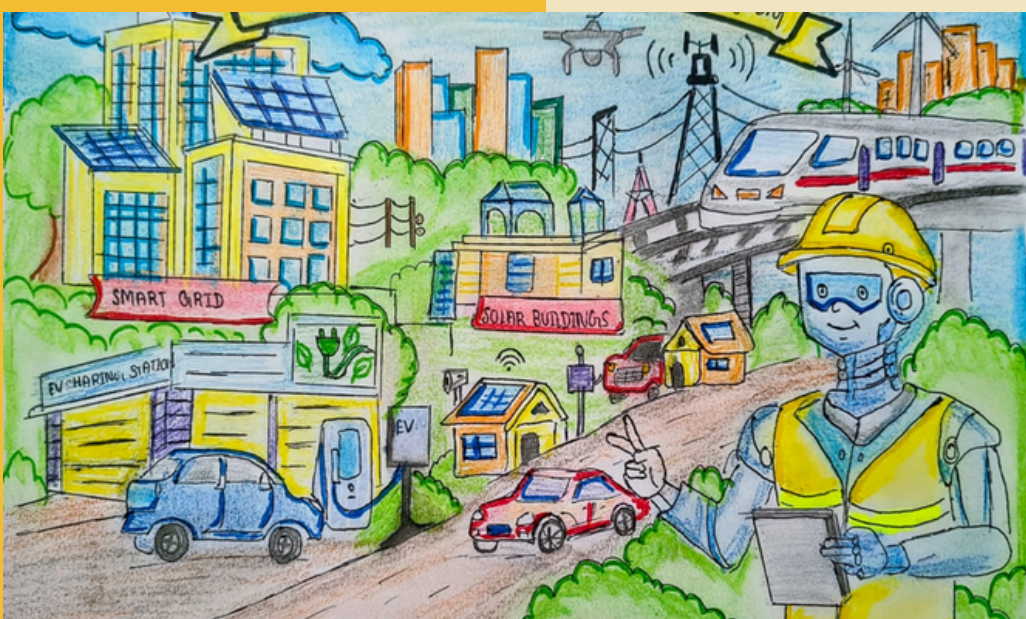

J.JEYA VINISHA
II YEAR EEE A



M.P.ASHA
II YEAR EEE A

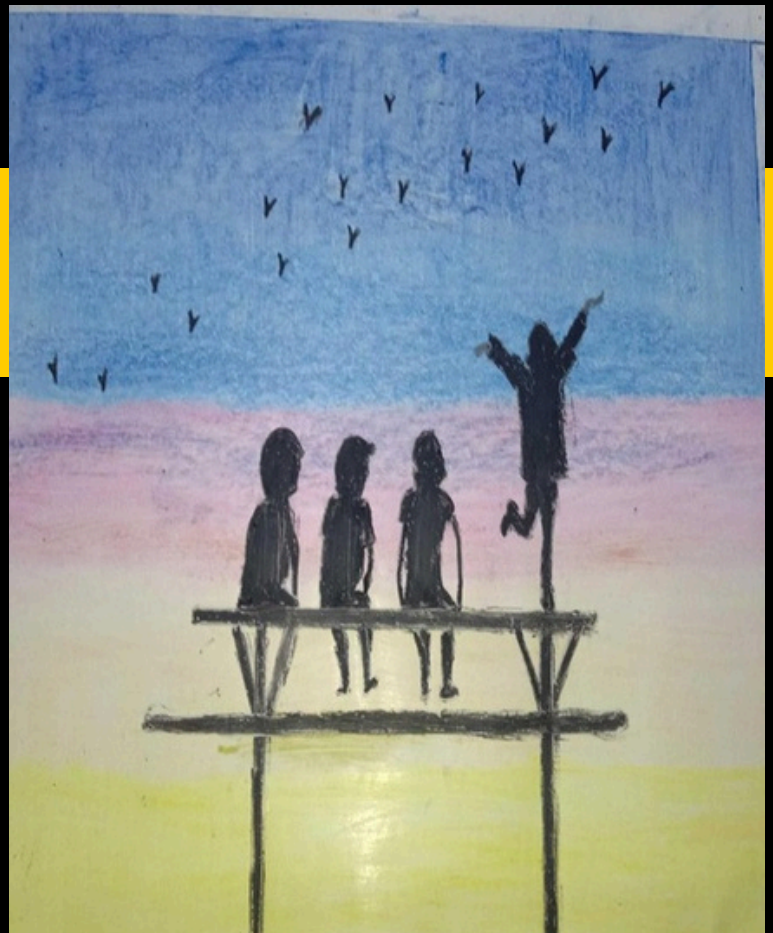

.P. SWATHI
II YEAR EEE A



EEE DEPARTMENT MAGAZINE



VELAMMAL COLLEGE OF ENGINEERING & TECHNOLOGY

(Autonomous)

NBA Accredited, NAAC Accredited with 'A'
Grade

